

THE ALL-TERRAIN  
**MINK 2.0**  
SPORTS CAMPER



**WILD AND FREE**



**MINK CAMPERS**

# Nordic Design Heritage

---

## CONNECT WITH NATURE

Whether it is a short weekend trip or a longer journey exploring new adventures and activities, we all need to connect with **nature**: there is a primitive part of our collective past that seeks connections with people and nature, storytelling, cooking food in a simple way, fetching water from the stream, and the secure, comfortable feeling of a warm shelter while being immersed in nature.

At **MINK of Iceland** we used our Nordic design heritage to create the MINK Sports Camper to enable even the most inexperienced individuals to stay and surround themselves in nature. We achieved this by removing all the discomforts and complexities that stop most people from venturing into the wild.

## SCANDINAVIAN MINIMALISM

The core of our design policy is intuitive functionality, sustainability, craftsmanship and durability. By always focusing on the essentials for **outdoor** living, we ensure that you can enjoy the beauty of nature in a safe, simple and fun way. We strive to combine the intimacy of camping with style and comfort, but in a minimalistic way.







# Sustainable Aerodynamic Design

---

**ONLY 520 KG**

Now is the time to rethink how we live and travel. With the MINK 2.0 Sports Camper, you finally have a solution to a more sustainable and healthier way to travel. The **aerodynamic shape** and frameless Solid Shell Structure™ (patent pending), combined with our choice of innovative materials, have allowed us to reduce the weight of the sports camper to only **520 kg**. At the same time, however, the extremely **low center of gravity** makes the MINK 2.0 very stable and comfortable on any terrain.

This aerodynamic, light-weight design opens up a variety of possibilities for using more environmentally friendly vehicles, such as **electric vehicles** (EVs) or any compact-sized car, to reduce the consumption of fossil fuels. It all adds up in the end! The earth and your wallet will thank you.







# The MINK 2.0

---

## ALL-SEASON, ALL-TERRAIN

The MINK 2.0 is a purpose-built sports camper that delivers more of everything: fun, capability and effortless freedom. The innovative, frameless Solid Shell Structure™ (patent pending) and the **robust**, galvanized steel chassis from AL-KO make the camper very stable and safe to tow due to its very **low center of gravity**.

The **33 cm road clearance** is handy in any off-road situation and makes the MINK a true all-terrain camper for any season. Whether it be gravel, snow, sand or a paved road, the camper will follow you wherever exploration takes you.

17" signature MINK Aluminum wheels are standard.

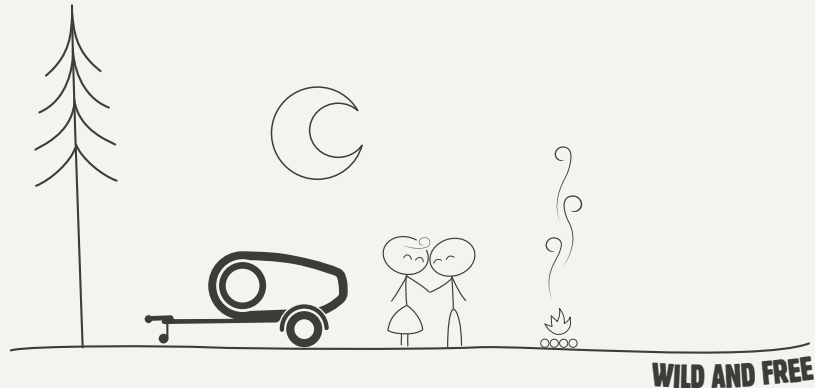



**WINTER**



**SPRING**



**SUMMER**



**AUTUMN**





# Interior space

## ROOM WITH A VIEW

The bright and spacious interior, with a panorama skylight and large, round side door windows, makes the MINK the perfect place to rest after long days out and about in the wild. This is the minimalistic, **Scandinavian master bedroom** in nature you have always dreamed about.

The **queen-size luxury mattress** (140×200 cm) fits two adults very comfortably and children love the canvas bunk bed (140×50 cm). The bunk bed can be removed or the height adjusted to allow for stowing supplies or clothes.

The side-wall-integrated **AirFlow™ system** (patent pending) keeps the camper ventilated, and when combined with the powerful Webasto heating system, warm air will flow into the cabin as well underneath the luxury mattress to keep you warm and dry all night (see page 14).

4 USB charging ports, 1 220v socket and the LED ceiling mood lights are standard.

Check out our MINK Interior Accessories, such as the duvet set and signature blankets.

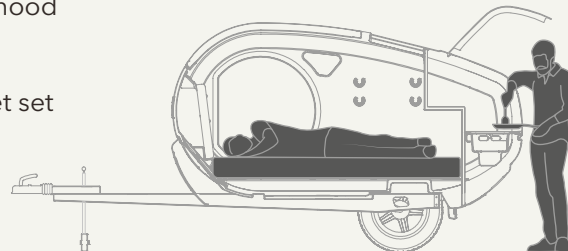



# Open-Air Kitchen

## COOKING IN NATURE

The back of the MINK has a spacious cooking area with plenty of storage: there is an illuminated 36L ice chest for cold drinks integrated into the high quality countertop, as well as a storage compartment with three removable boxes to store our **signature cube gas stove** with Scandinavian oak panels and additional cooking supplies.

The kitchen is equipped with a two level shelf system: the lower shelf stores the 3 easy-to-clean boxes and the upper shelf has robust cargo nets for extra supplies. A signature chopping board comes standard.

1 12v and 1 220v sockets are standard.

Check out our MINK cooking accessories, like the signature camping enamel dining set.

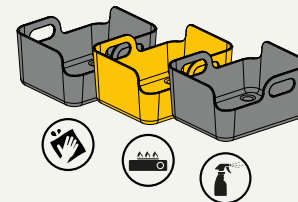
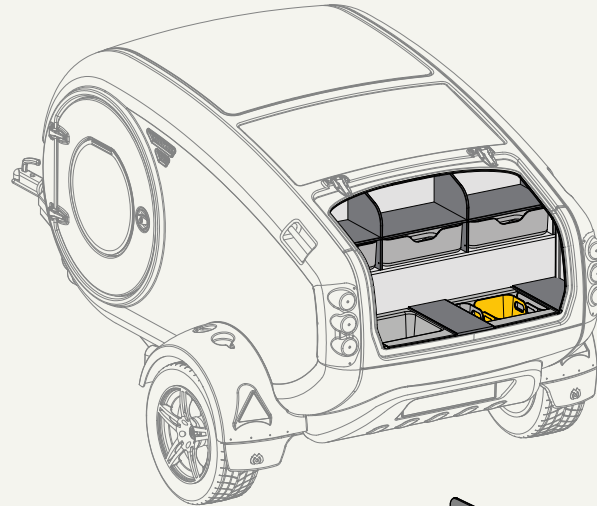
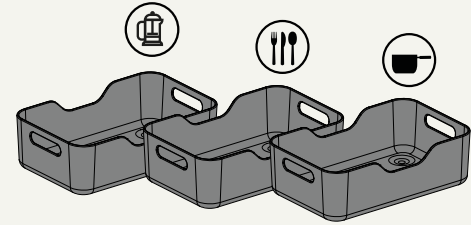





# Comfort and Safety First

## Sub-zero Temperatures

The MINK walls are 30 mm thick and made out of high-quality, fused ABS plastics and insulated with 19 mm Armaflex, a highly thermo-insulating material. This, in combination with the Webasto heating system, allows you to sleep comfortably in the MINK, even in extreme sub-zero temperatures.

## 2-year Limited Warranty

We offer a standard, two-year limited warranty on the patent pending **Solid Shell Structure™** against any structural damage or leakage, as well as on the AL-KO galvanized steel chassis.

## THE AirFlow™ SYSTEM

The two-way, side-wall-integrated AirFlow™ system uses negative pressure to allow air to flow freely out of the camper while driving. When not driving, however, air flows steadily into the camper without allowing dust or pollen to penetrate the filter system. This helps manage condensation.

## Robust Al-Ko Chassis

The AL-KO chassis is made from galvanized steel and comes standard with an overrun braking system, as well as hand and emergency brakes. The independent Torsion suspension system and shock absorbers ensure a smooth ride.

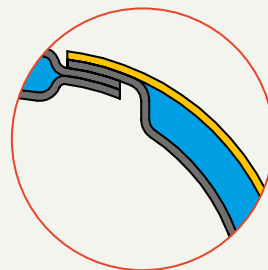

**19 MM Armaflex**  
insulation for cold nights



**2 year warranty**  
on Solid Shell Structure

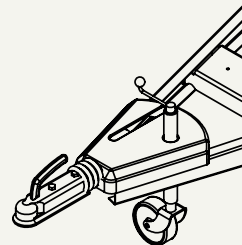

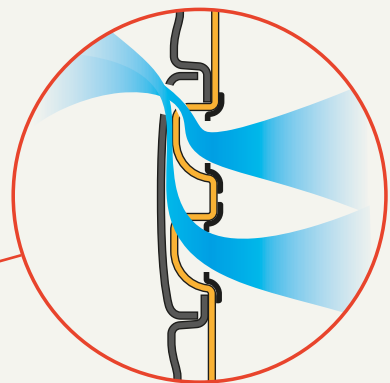
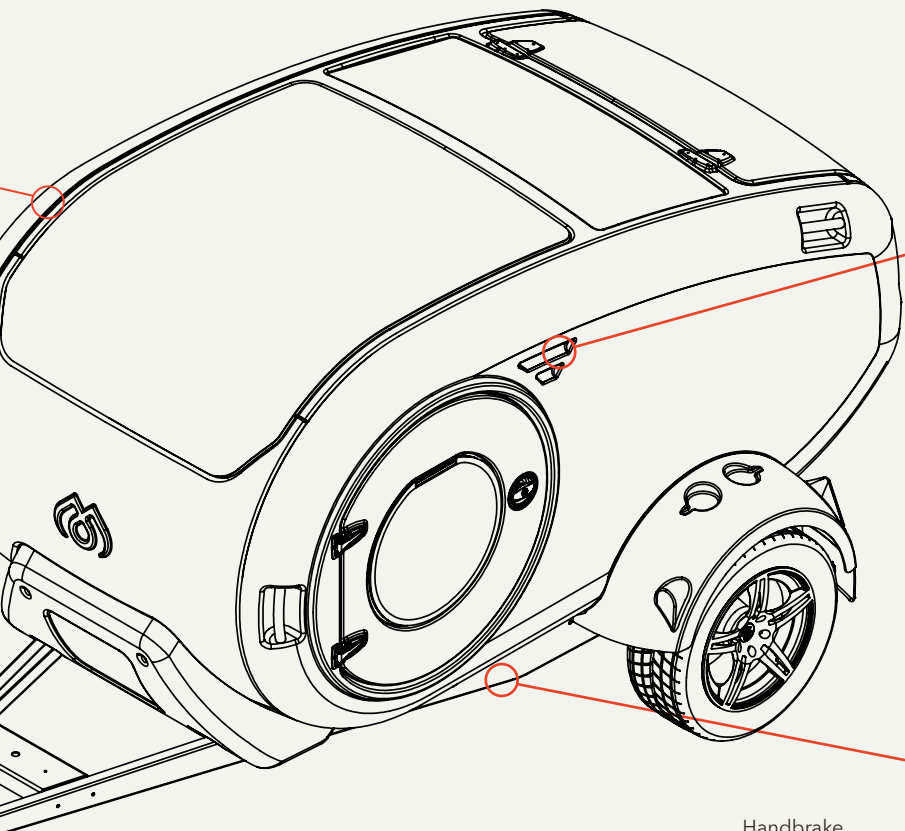

**AirFlow<sup>TM</sup>** active ventilation system

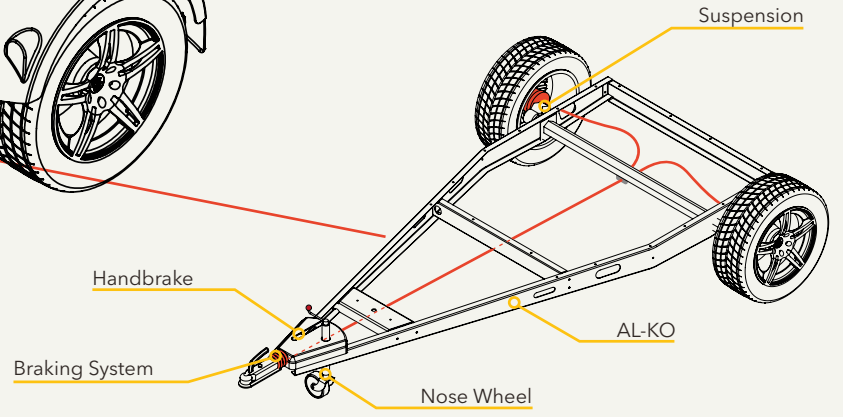



# Heating And Solar Panel

## INTEGRATED HEATING SYSTEM (extra)

Located in the front of the camper, the **integrated** heating is a cutting-edge solution for improving performance and reducing fuel consumption and engine maintenance. In combination with the **AirFlow™** system, 70% of the hot air flows into the camper cabin, while the remaining 30% is directed under our signature mattress to minimize condensation and heat the bed on cold nights. You will love it!

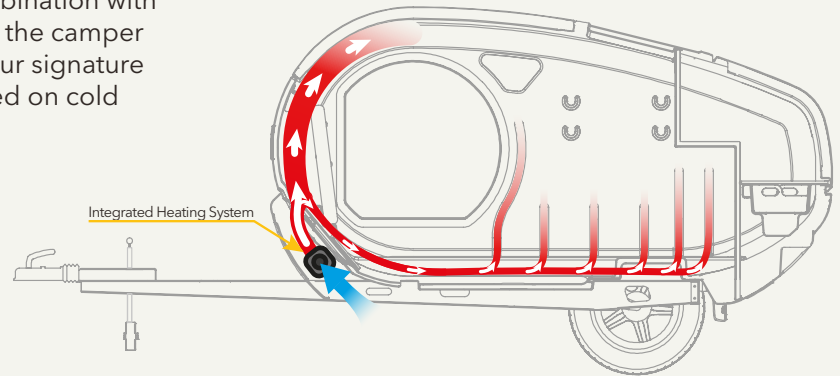

## CUSTOM MADE SOLAR PANEL (extra)

The solar panel is custom made and tailored to the MINK. The 105 W cell that is perfectly-suited for the MINK 2.0 and its power needs during off-the-grid adventures. The cell comes equipped with a Victron Blue Solar 75/10 charger regulator.

Solar Panel



# MINK Cargo

---

## **CARGO PLATFORM (extra)**

The front cargo platform allows you to store secured cargo bags and has an extra protective element for the camper and bike or ski racks, if installed.

## **FRONT CARGO BALL HITCH FIXTURE (extra)**

The hitch fixture, located in the front of the camper, allows you to interchange bike and ski racks systems.

## **BIKE RACK (extra)**

Our recommended bike rack allows for two mountain bikes to be transported in front of the camper.

## **SKI RACK (extra)**

Our recommended ski rack can accommodate 4 sets of skis and 2 snow boards.

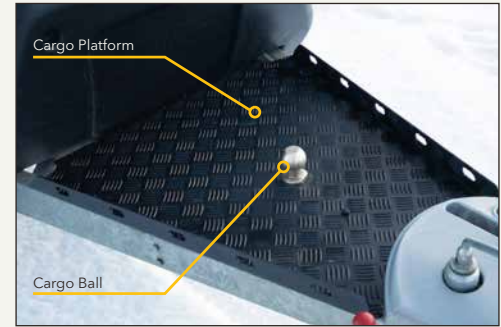

# STANDARD EQUIPMENT

## Exterior structure & suspension system

SOLID SHELL STRUCTURE™ made from fused ABS plastic material. Wall thickness 30 mm with 19mm Armaflex High thermal insulation

2× front and 2× rear rugged handles

AL-KO Chassis - reinforced galvanized steel

AL-KO mechanical hand break

AL-KO emergency breaks

AL-KO shock absorbers

13 pin electric trailer plug charges while driving

All Terrain tyres  
225x55x17 Tires

17" MINK aluminum wheels

Battery 70ah

1× 220w main electric connection

Reinforced galvanized steel battery protective storage box

DEFA Multi Charger 1205 Flex

## Interior space

Salvador upholstered head rest. Soft leather look with heavy duty 50.000 cycle abrasion tear resistance

140×200 cm (55"×79") quality memory foam mattress

140×50 cm (55"×20") heavy duck canvas bunk bed with 2 black oak dowels

Large panorama skylight window

Ceiling LED mood light

4× USB 12v sockets

1× 220v socket

Battery monitoring system

2× Large opening side windows

2× heavy duck canvas side window blinds

Heavy duck canvas blinds for Panorama skylight window

2× MINK storage pockets

2× side wall integrated static ventilation

## Open air kitchen

High quality 12 mm HPL counter top with integrated ice chest and storage compartment

3× large storage boxes in lower shelves

1× Custom MINK cube gas stove with Scandinavian oak side panels

3× storage shelves (upper)

Illuminated 36 L ice chest

Below storage area with 3 movable boxes

1× 12v socket

1× 220v socket

LED lighting

1× MINK sustainable wood chopping board

Kitchen hatch with integrated lift and latch locking

# SPECIFICATIONS & DIMENSIONS

Gross weight	750 kg / 1.654 lbs
Net weight	520 kg / 1146 lbs
Overall length	4116 mm / 162 inch
Cabin length	2811 mm / 111 inch
Overall height	1829 mm / 72 inch
Overall width	2080 mm / 82 inch
Cabin width	1511 mm / 59 inch
Road clearance	330 mm / 12 inch
Wheels	17×8.5×112
Tyres	225/55R/17
Tongue height	450 mm / 18 inch
Tongue weight	74 kg

